

# **FR-S13** *series*

## **USERS INSTRUCTION MANUAL**

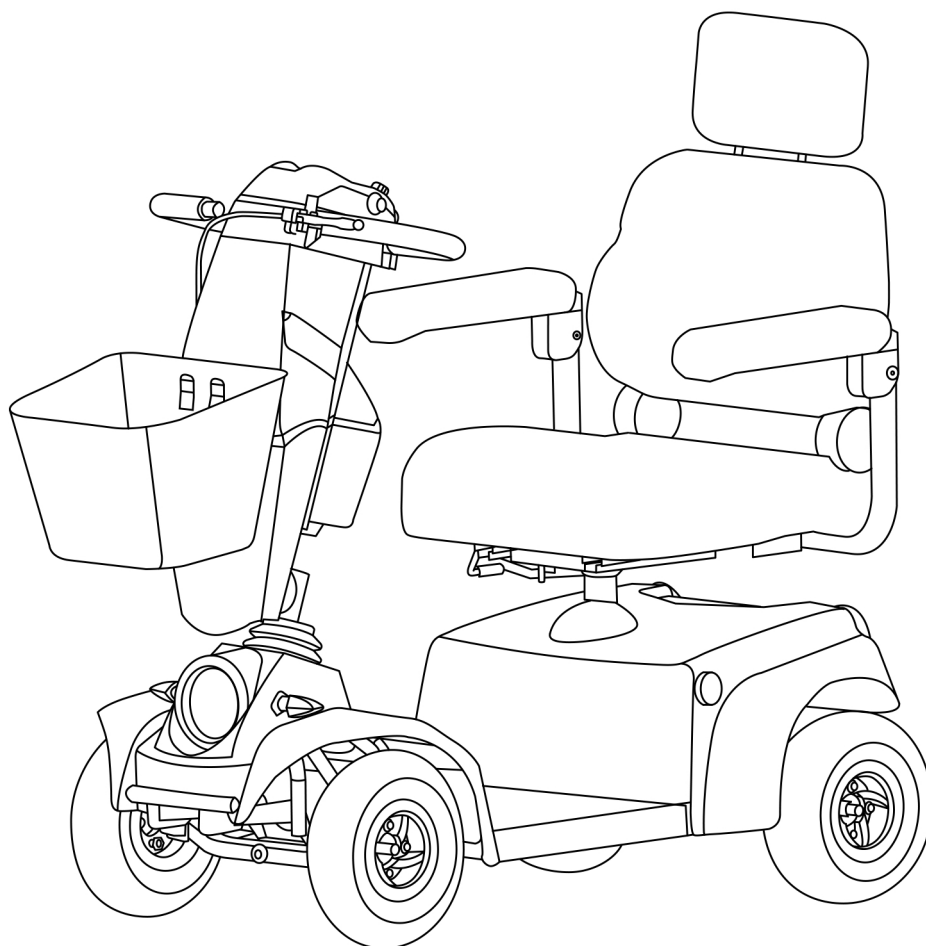

OPERATION



COMFORT



MAINTENANCE

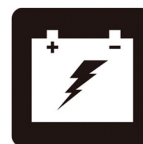

BATTERY CHARGING

# SAFETY GUIDELINES



**Warning!** An authorised provider or a qualified technician must perform the initial setup of this scooter and must perform all of the procedures in this manual.

The symbols below are used throughout this owner's manual and on the scooter to identify warnings and important information. It is very important for you to read them and understand them completely.



**Warning!** Indicates a potentially hazardous situation. Failure to follow the designated procedures can cause either personal injury, component damage, or malfunction.



**Caution!** Means if the precaution is not taken, it may cause minor or moderate injuries. We advise consumers to pay close attention in order to minimise the risks and damages.



These actions are prohibited. These actions should not be performed at any time or in any circumstances. Performing a prohibited action can cause personal injury and/or equipment damage.

## INTENDED USE

The intended use of the scooter device is to provide mobility to persons with limited mobility due to an injury, physical disability or medical condition which means that they are unable to walk or have difficulty in walking.

*Please fill out the following information for quick reference:*

<i>Supplier:</i> _____	
<i>Address:</i> _____	
<i>Phone Number:</i> _____	<i>Purchase Date:</i> _____

*Note: This manual contains the latest specifications and product information, we reserve the right to necessary changes, any change in the product may cause a slight difference in the illustration or description, the latest version of the user manual is available on our website.*

## CONTACT INFORMATION

If you have any question about the accessories, the parts you've ordered or the service you've received from FreeRider authorised dealer, please feel free to contact the manufacturers at the address below:

### **FREERIDER**

No.22, Bengong 5th Rd., Gangshan Dist.,  
Kaoshiung City 820, Taiwan(R.O.C.)

Tel : 886-7-6223093

Fax : 886-7-6230373

Email: sales@freerider.com.tw

<http://www.freerider.com.tw>

# CONTENTS

I.	INTRODUCTION .....	4
II.	PRODUCT DESCRIPTION .....	4
III.	ABOUT YOUR FR-S13 .....	5
IV.	FR-S13 FEATURE GUIDE .....	6
V.	BATTERIES AND CHARGING .....	13
VI.	BASIC TROUBLESHOOTING .....	16
VII.	FREQUENTLY ASKED QUESTIONS .....	19
VIII.	SAFETY WARNINGS & INSTRUCTION LABELS.....	21
IX.	OPTIONAL ACCESSORIES .....	24
X.	WARRANTY TERMS.....	25
XI.	SERVICE RECORD.....	27

# I. INTRODUCTION

Congratulations on the purchase of your scooter! Please read this User's Instruction Manual and Safety Guide carefully before you attempt to operate your scooter. Your User's Instruction Manual is your guide to safe operation and the maintenance of your scooter.

Before beginning to use your scooter, make sure that you have completely read and understood all instructions thoroughly. Please observe the "Guidelines For Safe Use" and the "Safety Instructions And Warnings" outlined in this manual and safety guide. If you have any questions concerning operation or maintenance, consult your authorised dealer.

Please keep in mind that the operator of the scooter is responsible for accidents or hazards to other people or their properties.

Your scooter has numerous features not found on other scooters. With proper care and maintenance, you will enjoy many years of dependable service from your scooter. Your scooter needs to receive proper maintenance at regular intervals and should be inspected frequently for proper mechanical operation. Troubleshooting guidelines, methods of detecting improper operation and how to make minor adjustments are all included in this manual.

Follow all recommendations to obtain trouble free, safe and enjoyable operation of your scooter. Please remember that when it comes to service and repairs, for more informations.

**When you are reading this manual, the word usages may not be the same due to regional difference.**

UK	US	UK	US
Authorise	Authorize	Kurb	Curb
Anti-clockwise	Counterclockwise	Motorise	Motorize
Centre	Center	Minimise	Minimize
Colour	Color	Neutralise	Neutralize
Customise	Customize	Travelling	Traveling
Familiarise	Familiarize	Tyre	Tire
Grey	Gray	Forwards	Forward

# II. PRODUCT DESCRIPTION

## FR-S13 SERIES CLASSIFICATION:

	Speed	
FR-S13	6 km	4 mile
FR-S13	10 km	6 mile
FR-S13	13 km	8 mile

*Note: Some styles will differ depending on the location of your authorised dealer.*

A range of accessories are available from your authorised FreeRider dealer to further customise your scooter needs. Under no circumstances should you modify, add, remove or disable any feature, part or function of your mobility scooter.

# III. ABOUT YOUR FR-S13

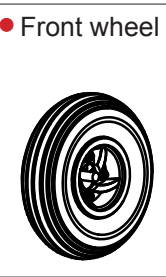
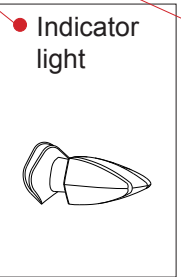
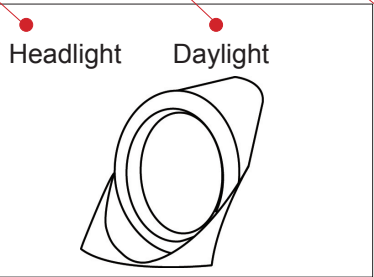
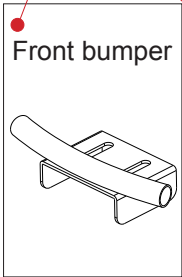
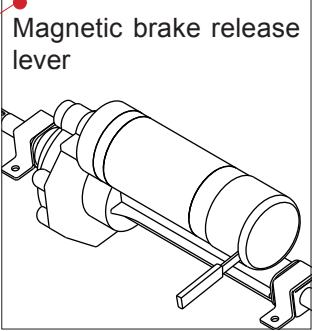
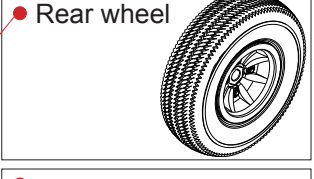
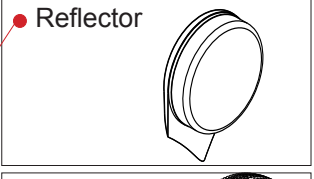
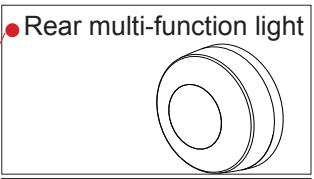
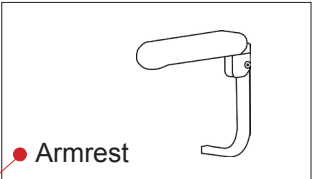
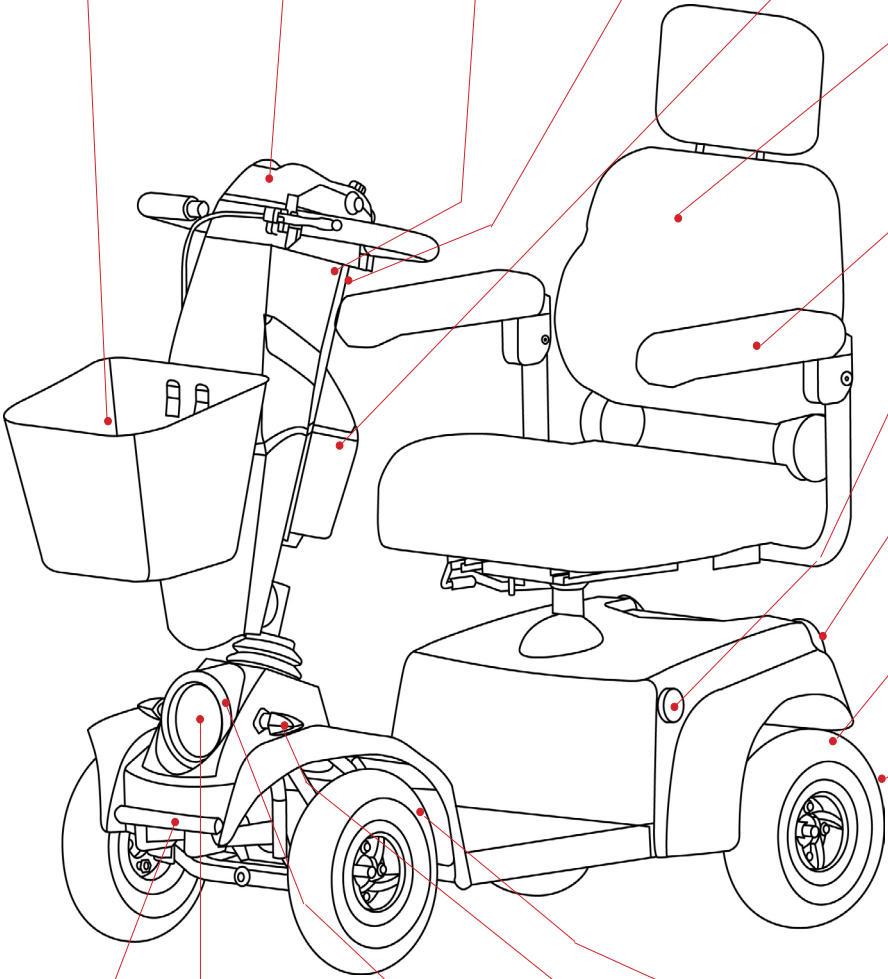
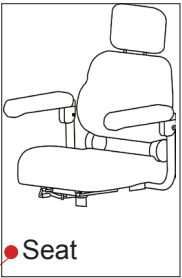
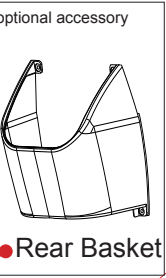
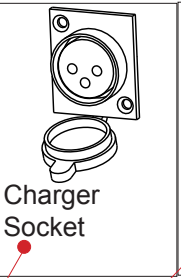
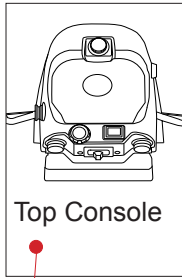
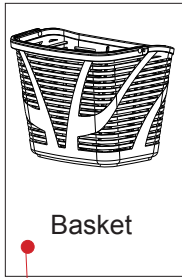

## IV. FR-S13 FEATURE GUIDE

### TOP CONSOLE FUNCTION OPERATION

The top console on the handle controls all functions, including forward/reverse/speed control/headlight/horn/indicator light/warning light/power status. Please refer to FR-S13 series functional classification on page 4.

- |                         |                              |
|-------------------------|------------------------------|
| 1. Warning light switch | 7. Indicator light switch    |
| 2. Key switch           | 8. Speed control knob        |
| 3. Power status meter   | 9. Hi/Lo switch              |
| 4. Wigwag               | 10. Handbrake                |
| 5. Headlight switch     | 11. USB socket               |
| 6. Horn                 | 12. Off-Board Charger socket |

### FR-S13 - 13km

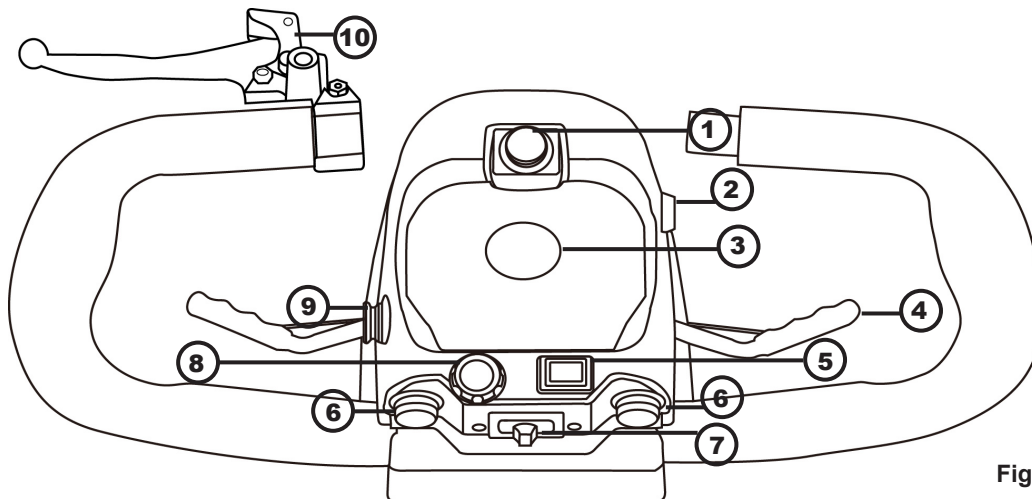

Figure 1.

### FR-S13 - 6km/10km

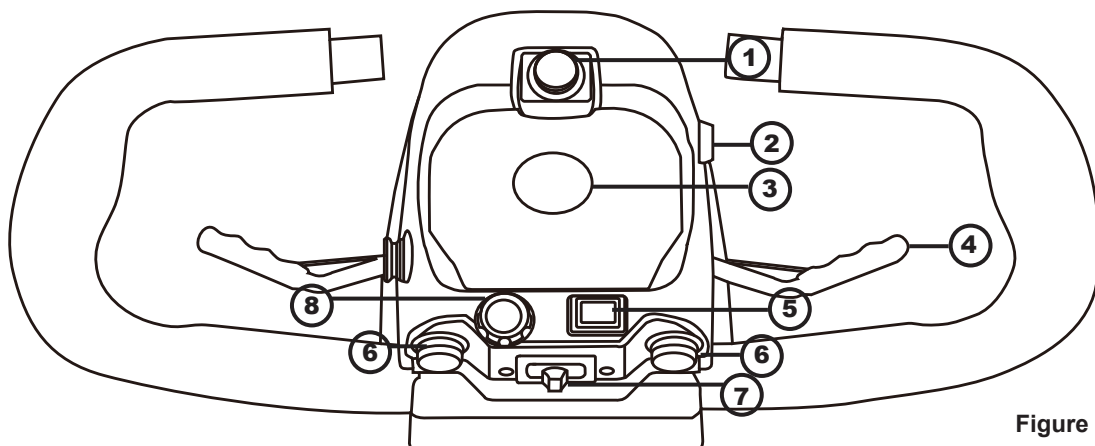

Figure 2.

## IV. FR-S13 FEATURE GUIDE

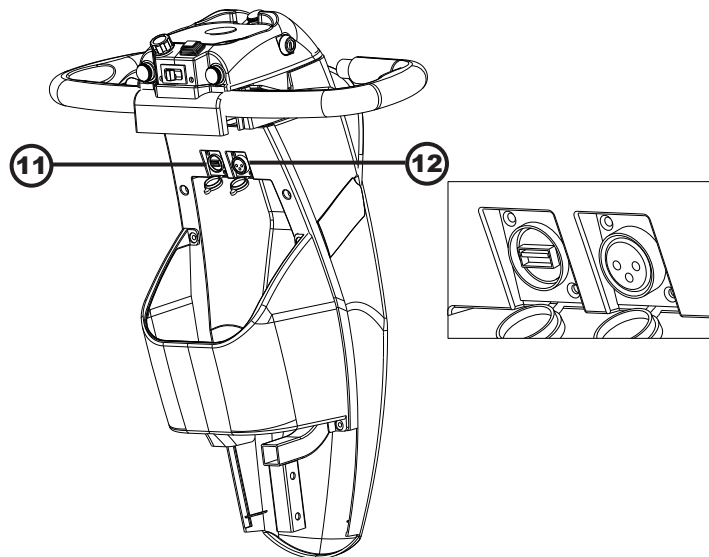

Figure 3.

### 1.Warning light switch

In case of temporary stop or sudden failure of scooter on the road, please be sure to use hazard warning light when the scooter is parked.

### 2.Key switch

Insert the key and turn clockwise. You will notice that after a second, the LED on the battery state indicator moves towards the sector and the power light illuminates. Your scooter is now ready to drive. To switch off your scooter, turn the key anti-clockwise. Remove the key when your scooter is left unattended. DO NOT attach heavy additional keys to your key ring since the weight can damage the switch unit.



## Warning!

- If the power switch is moved to the "OFF" position while your scooter is in motion, the electronic brakes will engage and your scooter will come to an abrupt stop!

## IV. FR-S13 FEATURE GUIDE

### 3. Power status meter

The power status meter contains the battery meter/ direction indicator and the fault indicator. Please refer to on Figure 4.

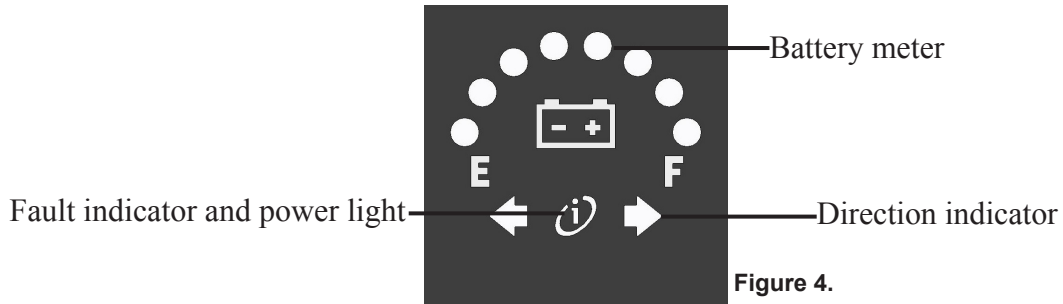

Battery meter LED from left to right, LED colour are red /orange /green.

LED from left to right	Colour
1	Red light
2~3	Orange light
4~8	Green light

When you turn your scooter on, the fault indicator and power light on your console will illuminate at a constant rate. The status light is connected to a very sophisticated diagnostic system, which can identify faults which could occur on the main speed control system or some other part of your scooter's electronic drive system. For instance, if your batteries run low on power, the status light will flash slowly at one flash per second, this indicates that your batteries need recharging. If you notice the status light flashing at two flashes per second, you are being notified that the battery voltage is too low and you must stop using your scooter at the earliest opportunity. Your status light has nine similar flashing diagnostic signals, reference to these diagnostic codes is found under "Fault Finding" at the rear of this manual.

### 4. Wigwag

Located under the handlebar grips. Your speed for forwards and reverse motion and braking is controlled here. Control the rate of speed by pressure applied to lever. When you release the lever, it will return itself, and you'll gently stop. Figure 5.

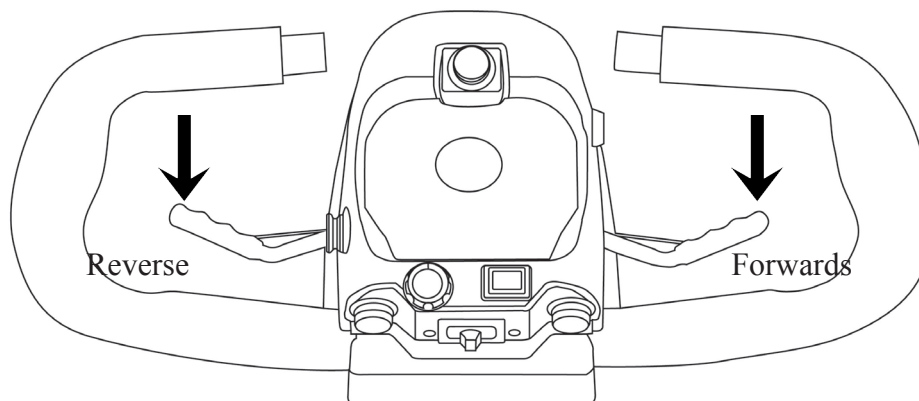

Figure 5.



## IV. FR-S13 FEATURE GUIDE

### 5. Headlight switch

Turn on the switch to open the headlight and rear lights. The headlight bulb and LED for rear lights of this FR-S13 series is 12V.

### 6. Horn

Press the horn button to sound the horn. The horn will sound for as long as the horn button is pressed.

### 7. Indicator light switch

When you are making a turning manoeuvre on the road, the appropriate switch indicator warning light will flash. To cancel the direction indicator, return the switch to the centre position. The left direction indicators are activated by "flicking" the switch to the left. At the same time, the direction indicator on the power status meter will flash too. Please refer to Figure 4.

### 8. Speed control knob

This allows you to pre-select your desired top speed. The dial is proportional to speed and can be set anywhere between minimum ("min") and maximum ("max") increments. Turn the dial knob anti-clockwise to minimum for a very gentle operation, and clockwise towards maximum to increase your speed. Remember the higher the position the speed dial is set to, the faster the scooter will be.

### 9. Hi/Lo switch

When indoors or in a pedestrian area, the low 4 mph speed range must be engaged, choose to use "LOW" gear. The Hi/Lo speed range switch can be operated while the scooter is in motion.

Note: This feature is only used in 8 miles/13km/h mode.

### 10. Handbrake

The lever when pulled towards you, operate two front drum brakes. This manual braking system works independently of the main electronic braking system and must only be used in an emergency situation. For instance, if the transmission becomes disconnected, you will need to brake your scooter.

To operate the manual brake, simply squeeze the lever towards the handlebars, the harder you squeeze the more pressure will be applied to the brakes.

Note: This feature is only used in 8 miles/13km/h mode.

### 11. USB socket

The USB connector on the left hand side of the charge socket allows you to charge the small electronic devices (output 5V/1A).

Note: Using USB will reduce scooter's battery capacity.

### 12. Off-Board Charger socket

Your scooter has a lot of power. To ensure it works to its full potential, you must maintain both batteries on full charge. Nightly recharging will give the batteries longer life and ensure your scooter when you are ready to go. Only use the charger supplied with your scooter; other makes of charger may permanently damage your batteries and would invalidate the guarantee.

## IV. FR-S13 FEATURE GUIDE

### HANDLEBAR ADJUSTMENT

The handlebar of your scooter is designed to allow you to position it in a comfortable driving position. It can be locked into numerous positions or unlocked to move freely for transportation. The handlebar lock is operated by a black knob positioned on the right hand side of the handlebar.

To release the handlebar from a locked position, release the black knob in a clockwise direction, the handlebar will now move freely, but under mild tension.

After adjusting the appropriate comfortable operating position, turn the knob anti-clockwise to fix the handle.

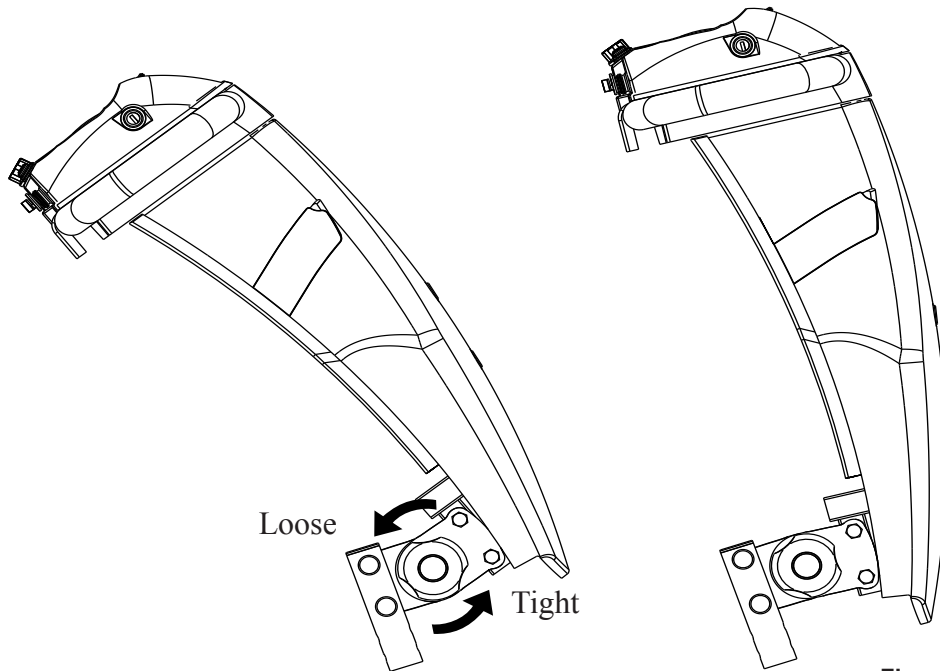

Figure 6.

## IV. FR-S13 FEATURE GUIDE

### SAFETY BELT

On some models, scooter seat is fitted with a safety belt to prevent you from slipping forwards under braking conditions or while going down a slope or over obstacles, always use it-even for short journeys.

The lap belt can be adjusted on one side to fit comfortably around your waist. To fit, simply connect the two buckles together until a distinct "click" is heard. To remove, simply press the "red" buckle and the two belts will separate.

### ARMREST WIDTH ADJUSTMENT

On each side at the rear of the seat, you will find a large black knob. By simply loosening this knob you will be able to slide the armrests in or out to whatever width you desire. Re-tighten the knobs fully.

### SEAT HEIGHT ADJUSTMENT

You may need to alter the seat height setting at a later date, please follow these instructions.

(A) Remove your seat from the scooter by lifting the seat.

(B) With the aid of a 16mm wrench loosen the 10mm seat clamp fixing bolt from side of seat post. Remove the 10mm fixing bolt and reposition the bolt into one of the four preferred location holes of the seat mounting tube.

(C) Re-tighten the 10mm fixing screw.

(D) Refit the seat onto your scooter.

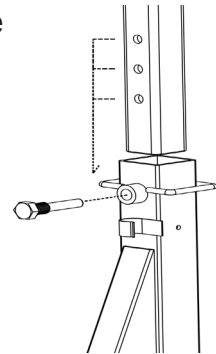

### SEAT SLIDE

Located on the right front side of the seat. The lever allows you to adjust your seat forwards and backwards while sitting on the seat. Simply pull up the lever and move in the desired position backwards by pushing or forwards by hitching. As soon as the lever is released, the seat will lock into the new position.

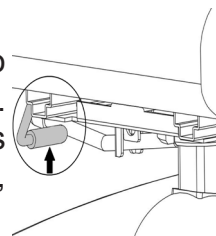

### HEADREST HEIGHT ADJUSTMENT

The upper cushion of your backrest can be adjusted for height, giving you more back support if you are tall, by operating the small latch at the base of the left hand round support bar. Lift the cushion up or push it down for the most comfortable position. The headrest will also lift out for convenience.

### SLEEP MODE

When your scooter has been idle for 15 minutes or more, it will automatically go into sleep mode to conserve its battery life. The system can be woken from sleep mode by turning the key switch.

## IV. FR-S13 FEATURE GUIDE

### FREEWHEEL PROCEDURE

Your scooter is equipped with a manual freewheel mechanism for your convenience when you need to push the scooter.

- To put your scooter in freewheel mode, locate the magnetic brake release (red handled lever) situated in the rear right hand side of your scooter under your seat. Make certain the power switch is switched off.
- Push the magnetic brake release (red handled lever) until a distinct click is felt to disengage the magnetic brake. You can now push your scooter with ease.



D = Drive (Brakes on the upside; unit in Drive Mode)



N = Neutral (Brakes Released; unit in Freewheel Mode)

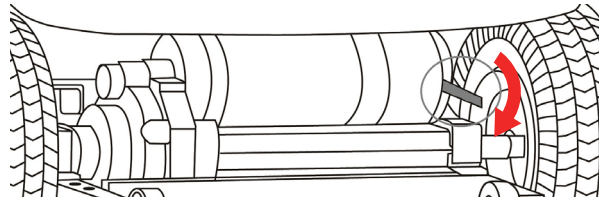

*Note: When your scooter stops in the freewheel mode while pushing, it is not stuck or broken. The safety feature on the scooter will automatically trigger when the scooter is pushed quicker than a slow walking speed.*

To engage the drive system, simply pull the magnetic brake release lever backwards until a distinct "click" is heard. If the power switch was left on while in freewheel mode, simply power off and then on to enable driving mode.



## Warning!

- **If your scooter is in the freewheel mode, you will not be able to drive. Dismount and re-engage the drive system by pulling back on the magnetic brake release (red handled lever). Remount on your scooter. Switch the power off and on to clear the fault. Your scooter will now drive again.**
- **Always double check that the freewheel mechanism, and magnetic brake release lever is disengaged or in the drive position before attempting to drive your scooter after it has been left unattended for a period of time. Failure to observe this warning may result in an accident.**

**Sit on your scooter with the freewheel mechanism in the disengaged position. Your scooter has limited braking while in freewheel mode.**

**DO NOT use your scooter in freewheel mode without an attendant presents as this may result in a personal injury.**



**DO NOT attempt to personally disengage your scooter in the freewheel mode while seated on the scooter since a personal injury may happen. Ask an attendant for assistance.**

**It is unsafe to store the scooter in a vehicle or while on moving transport like a train while the scooter is in freewheel.**

*Note: If you are able to push your scooter while in the drive mode, the drive system may be disconnected. DO NOT attempt to drive your scooter.*

## V. BATTERIES AND CHARGING

### BATTERY INSTALLATION

Your scooter is equipped with two maintenance free 12 volt batteries. The batteries are linked together by wiring cables to supply the electronic system with 24 volts of power.

**Warning:** It is imperative that the two batteries are connected correctly to prevent a short circuit between the two batteries. When first installing the batteries, follow these assembly instructions.

- (1) Connect the labeled positive (+) wire to the positive (+) terminal of the battery, with the screw, nut and washer provided.
- (2) Connect the labeled negative (-) wire to the negative (-) terminal of the battery, with the screw, nut and washer provided.
- (3) Repeat this procedure on the second battery, making certain the plastic red/black terminal covers are secured over each terminal.
- (4) Sit on the seat and switch on your scooter, the battery meter will now move to show the state of charge in the batteries and your scooter is ready to drive.  
Please refer to **Figure 7**.

Batteries circuit diagram

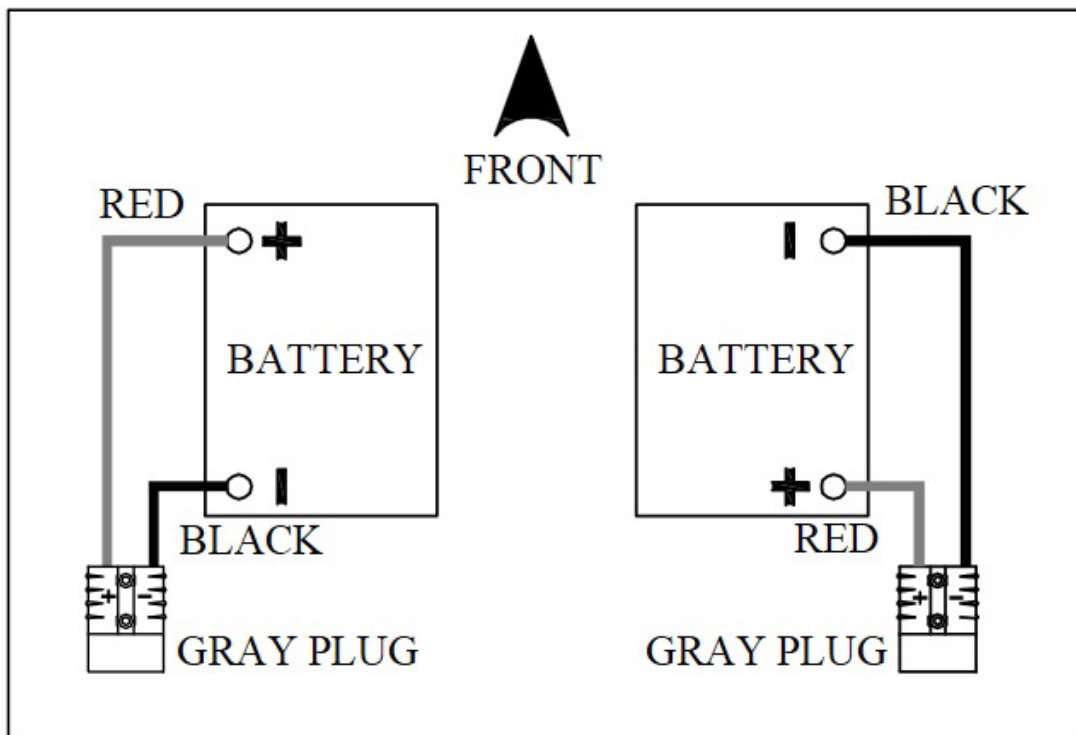

Figure 7.

## V. BATTERIES AND CHARGING

### BATTERY CHARGER

The battery charger is designed especially for your scooter. It is not suitable for any other powered mobility product. Only use the charger supplied with your scooter. The use of other chargers may permanently damage your battery and would invalidate the warranty.

#### Charging step:

- A. Charge the scooter in a dry room with no flammable materials around.
- B. Turn the key switch to the "OFF" position.
- C. Plug in power and connect scooter.
- D. The general charging time is 8 hours.
- E. Remove charger power cable after charging.

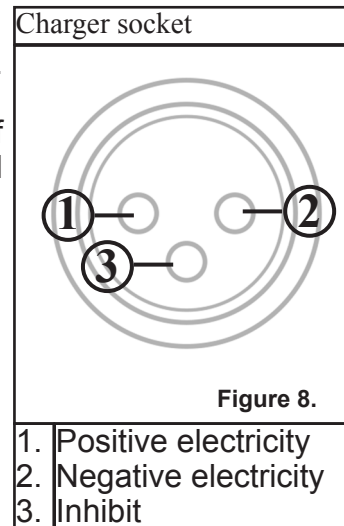

*Note: Your scooter will not drive if the charger is connected.*

### CHARGING YOUR BATTERIES



**PROHIBITED!** The removal of grounding prong can lead to electrical hazard. If necessary, properly install an approved 3-pronged adapter to an electrical outlet having 2-pronged plug access.



**PROHIBITED!** Never use an extension cord to plug in your battery charger. Plug the charger directly into a properly wired standard electrical outlet.



**PROHIBITED!** Do not allow unsupervised children to play near the scooter while the batteries are charging.



**MANDATORY!** Read the battery charging instructions in this manual and in the manual supplied with the battery charger before charging the batteries.



**WARNING!** Explosive gases may be generated while charging the batteries. Provide adequate ventilation while charging the batteries. Keep the scooter and battery charger away from sources of ignition, such as flames or sparks.



**WARNING!** You must recharge your scooter batteries with the supplied off-board charger. Do not use an automotive-type battery charger.

**WARNING!** Inspect the battery charger, wiring, and connectors for damage before each use. Contact your authorised provider if any damage is found.

**WARNING!** Do not attempt to open the battery charger case. If the battery charger does not appear to be working correctly, contact your authorized Provider.

**WARNING!** Be aware that the battery charger case may become hot during charging. Avoid skin contact and do not place on surfaces that may be affected by heat.



**WARNING!** If the battery charger is exposed to adverse or extreme weather conditions, then it must be allowed to adjust to the difference in environmental conditions before use indoors. Refer to the manual supplied with the battery charger for more information.

## V. BATTERIES AND CHARGING

### SAFE & LASTING BATTERY

1. For the longest battery life, your battery should be re-charged when the battery meter indicator is in the red region or after use whenever possible.
2. If your battery will not be used for an extended period, fully charge the battery and disengage from the battery compartment of the scooter before storage. Battery charge will gradually deplete with time. Please do a refresh charge every month when the battery has been stored for an extended period of time. (Remember: Keeping your battery charged will help extend the life of your battery and ensure that the scooter is ready to go when you are.)

### FR-S13 CHARGER STATUS LIGHT INDICATOR

- Orange: charging.
- Flashing Green: 3/4 charged.
- Solid Green: charging complete.

### GENERAL

Depending on the depth of discharge, the minimum time to recharge serviceable batteries fully will vary from 8 hours up to 12 hours. Please note that recharge time will vary between the minimum and maximum times indicated due to the varying states of battery use. Please be patient.

## VI. BASIC TROUBLESHOOTING

When the scooter fails, most of the time the reason is due to the loss of electromechanical functions. Usually, the scooter can operate normally through some simple recovery or through the fault indicator. The fault indicator please refer to "Status Fault Codes". If there are any problems or problems that cannot be suspected, please contact your authorised dealer.

### **If your scooter will not start:**

Check the power key switch is turned "on". If it is, the battery condition indicator meter will be operating. If the status light on your console is flashing, please refer to "Status Fault Codes".

### **If the battery condition meter and the status light fail to operate when the key switch is in the "on" position, check the following:**

- A. Make sure the battery charger is not plugged into the tiller charge socket, this will prevent drive.
- B. Check both battery connectors. Check battery terminal condition.
- C. Check the "circuit breaker" or fuse.
- D. If your scooter stops for no apparent reason, it is probably due to the circuit breaker disconnecting from the speed control electronic box.

### **Recommended fuse rating:**

One fuse protects your scooter charging circuit from receiving an overload of electrical current. The fuse used in the scooter is the same type which is found on automobiles. In the unlikely event that a fuse should 'blow' and needs replacing. Please use fuse with the recommended fuse rating. Please note that this size of fuse has been selected to give your scooter the best protection without premature fusing.

1. Charger 10A.
2. Lights circuit 10A.



## **Warning!**



**Please confirm to the recommended fuse rating, or may cause permanent failure to the wiring and wiring connectors or personal injuries. For access to a fuse, removing the rear cover, lift cover locate and lift the fuse block, lift up the fuse lid. Replace the blown fuse and close fuse lid and replace fuse block.**

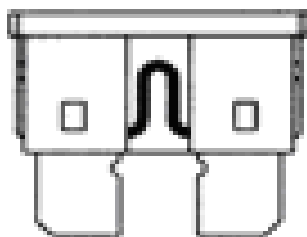

**Working Fuse**

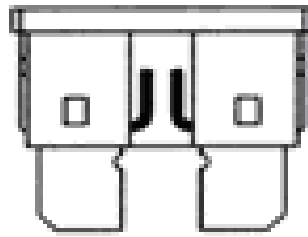

**Blown Fuse**



## VI. BASIC TROUBLESHOOTING

### Status Fault Codes:

Flash	Description	Meaning
1	Battery Low	The batteries are running low. ●Recharge the batteries.
2	Low Battery Fault	The batteries have run out of charge. ●Recharge the batteries. ●Check the battery and associated connections and wiring.
<p><i>Note: The low battery fault flash code, described above, is a requirement of various safety standards. The scooter will output a visible and audible low battery warning if the battery voltage drops below 90% of its cut-off voltage.</i></p> <p><i>The warning will be two short flashes, and will take priority over all other flash codes in the system.</i></p>		
3	High Battery Fault	Battery voltage is too high. This may occur if overcharged travelling down a long slope. ●If travelling down a slope, reduce your speed to minimise the amount of regenerative charging.
4	Current Limit Time-out	The motor has been exceeding its maximum current rating for too long. ●The scooter may have stalled. Turn the controller off, leave for a few minutes and turn back on again. ●The motor may be faulty. Check the motor and associated connections and wiring.
5	Park Brake Fault	Either a park brake release switch is active or the park brake is faulty. ●Check the park brake and associated connections and wiring. ●Ensure any associated switches are in their correct positions.
6	Throttle OONAPU (Out Of Neutral At Power Up)	Either a stop function is active or a charger inhibit or OONAPU condition has occurred. ●Release the Stop condition (seat raised etc.) ●Disconnect the battery charger ●Ensure the throttle is in neutral when turning the controller on. ●The throttle may require re-calibration.
7	Speed Pot Fault	The throttle, speed limit pot, their associated wiring may be faulty. ●Check the throttle and speed pot and associated connections and wiring.
8	Motor Voltage Fault	The motor or its associated wiring is faulty. ●Check the motor and associated connections and wiring.
9	Other Error	The controller may have an internal fault. ●Check all connections and wiring.

## VI. BASIC TROUBLESHOOTING

### TYRES

Check the condition of your tyres regularly. Look for signs of wear, cuts and foreign objects lodged in the tread. Maintain the tyre pressures at all times; failure to comply with this can lead to poor performance of your scooter and could make your scooter unsafe or unstable. Tyres should be replaced when the tread is worn to 0.5mm.

### REPLACEMENT TYRES

If scooter tyres are worn or damaged, when it must be replaced, contact your authorised dealer for more information regarding replacement wheels for your scooter.



## Warning!

**WARNING! Wheels on your scooter should only be serviced/replaced by a qualified technician.**

### CHARGER FAULT DIAGNOSIS

- A. If the green indicator is off, check the AC input. If the AC input works normally, the battery charger may be defective.
- B. If the green indicator is working normally but the charging indicator (orange) is off, the polarity connection may be reversed. The output connection may be short or open. If the charging indicator (orange) is still off while charging, the battery charger may be defective.
- C. If the charging indicator (orange) does not turn green (charged state), the battery is not being charged normally. Please stop charging and have the battery repaired or checked by an authorised scooter service centre.
- D. If the charging indicator goes from orange to green (fully charged state) immediately, the battery may be fully charged.
- E. If the battery does not charge, the battery may be defective. Have it checked by an authorised scooter service centre.

### MOTOR FAULT DIAGNOSIS

Whilst the scooter is being driven, if you notice unusual changes in speed and or vibration is felt or heard then please check the motor carbon brushes for excessive wear or pitting. There is usually a wear indicator on the motor carbon brush. Contact your authorised scooter service centre. Provide the motor model to obtain the corresponding carbon brush specification for replacement.

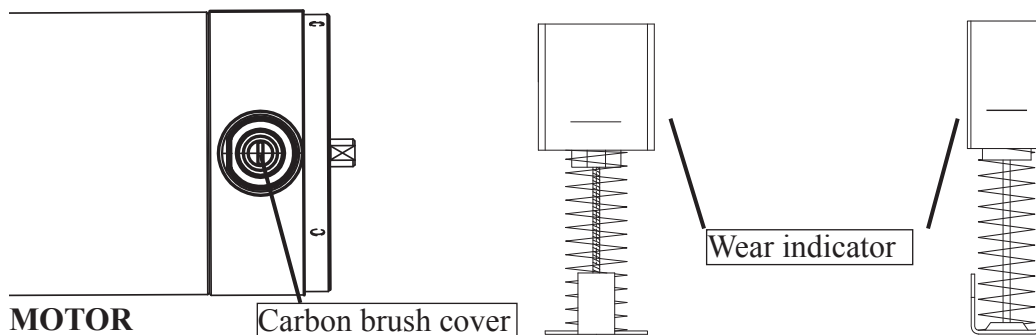

## VII. FREQUENTLY ASKED QUESTIONS

**Q: Who should I contact if I need replacement parts for my scooter?**

**A:** Contact your authorised dealer for replacement parts on your scooter.  
Please refer to page 2 "**CONTACT INFORMATION**".

**Q: When should I charge my battery?**

**A:** Charge your battery when the battery indicator is in the red region on the battery indicator on the console of your scooter.

**Q: How can I get the maximum operating time per charge?**

**A:** Rarely do we have the ideal driving situation (e.g. smooth, flat, hard terrain with no wind or curves and warm temperatures). More often, we are presented with hills, uneven and loosely packed surfaces, curves, wind, cold and heavy loads. Conditions described above will affect the distance or running time of your battery charge.

Here are a few suggestions for obtaining the maximum range per charge:

- Always charge your battery fully prior to your trip.
- Plan your trip in advance to avoid inclines, curbs and soft surfaces.
- Limit your baggage weight to essential items.
- Try to maintain an even speed to avoid stop and start driving.
- Ensure recommended routine servicing of the vehicle's components.
- DO NOT allow metal objects to short out the terminals of your battery. This could cause the battery to explode and result in injuries.
- DO NOT allow your battery to freeze. If frozen, allow it to naturally thaw out before charging, failure to observe this warning may damage the battery.
- If you need to replace your battery, contact your authorised scooter provider.
- Always handle battery with care.

**Q: What if my scooter will not start?**

**A:** Check to see whether the power switch has been switched 'on'. If it is, the battery indicator meter will be operating. If the status light on your console is flashing once per second, your battery is low in charge. Charge your battery.

**Q: What if the status light on the power switch fail to operate when the switch is in the 'on' position?**

**A:** Make sure the charger is not plugged into the charge socket of your scooter. When your scooter is being charged, you will not be able to drive.

**Q: What if my scooter stops for no apparent reason?**

**A:** Your battery may not be working properly or if the park brake is mechanically released or the park brake is faulty, the scooter will not be able to drive. A park brake Error flash code will occur and the scooter will not be able to drive. If the scooter moves at a higher speed than Anti-Rollaway max speed, the controller will automatically power-up and then slow the scooter down, using dynamic braking, until it stops. Contact your authorised dealer.

## VII. FREQUENTLY ASKED QUESTIONS

**Q: What if the battery indicator is operational but the status light flashes and the scooter is inoperable?**

- A: 1. Check the status fault codes indicated by the LED on your power switch flashing.  
2. Usually is the magnetic brake release is not disengaged. If the magnetic brake release is disengaged, the status light on the power switch will flash 5 times.

**Q: What if my scooter does not slow down or behave erratically?**

- A: Switch off the power and contact your authorised dealer.

**Q: Does the scooter go to sleep mode when it is idle for a long period of time?**

- A: Yes, the scooter will go to sleep mode when idle for over 15 minutes.

**Q: How do I wake the scooter once it is in sleep mode?**

- A: The recommended way to wake the scooter is to power off the scooter before powering it back on.

# VIII. SAFETY WARNINGS & INSTRUCTION LABELS

## INSTRUCTION LABELS

The following labels are positioned on your scooter. These labels illustrate important warnings or instructions regarding the safe operation of your scooter. Please familiarise yourself with their location.



Located on handle cover

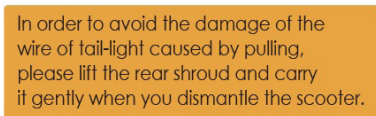

Located on rear cover



Located on rear cover

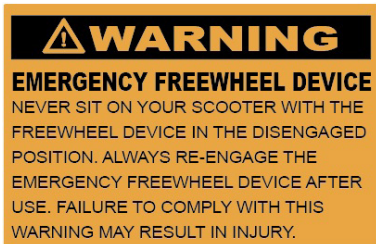

Located on rear cover



Located on handle cover



Located on handle cover



Located under front chassis



Located on rear cover



Located on handle cover

## VIII. SAFETY WARNINGS & INSTRUCTION LABELS

### SAFETY CONFIRMATION

In order to understand your scooter's capabilities. We recommend that you read the "Freerider Safety Guide" before use to ensure your safety and the smooth operation of the scooter.

Your scooter is a powerful machine. Please read all of the instructions in this manual before operating your scooter. Follow notes carefully to ensure safety at all times.

1. **ONLY** drive your scooter if your health condition allows you to be safe.
2. **DO NOT** carry passengers or exceed the maximum carrying weight.
3. **DO NOT** drive your scooter where you cannot safely or legally walk.
4. **DO NOT** drive your scooter unless the seat is locked into the driving position.
5. **DO NOT** drive your scooter in a confined space unless the speed adjustment dial is set low.
6. **DO NOT** turn suddenly at full speed, especially on an uneven or a sloping ground.
7. **DO NOT** drive when you are under the influence of alcohol or certain drugs which may impair your safety.
8. **ALWAYS** keep your feet on the vehicle while driving.
9. **ALWAYS** avoid uneven surfaces.
10. **ALWAYS** consult your doctor or your therapist if in doubt about your ability to operate a scooter.
11. **ALWAYS** strap down your scooter while transporting it in a vehicle and then transfer to the vehicle seat.
12. **DO NOT** drive on motorways, (e.g. those with a speed limit of over 50mph), cycle lanes or in bus lanes.
13. **ALWAYS** switch your lights on at night or in poor visibility. Wear reflective clothing.
14. **DO NOT** arbitrarily modify your scooter.
15. Please remember you are a motorised pedestrian and must observe all rules and regulations of other pedestrians wherever possible. Your scooter has been designed for use on most roads. However, you still must drive it with

## VIII. SAFETY WARNINGS & INSTRUCTION LABELS

### DAILY CHECKS

1. After using the scooter every day and charging the battery, check if the charger's light is normal, please refer to page 14 and 15 on "**BATTERIES AND CHARGING**".
2. Check if all button functions on the top console are normal, please refer to page 6 on "**FR-S13 FEATURE GUIDE**".
3. Operation of motor brakes
4. Operation of driving brake
5. Operation of seat lock
6. Tyre condition
7. Battery capacity

### WEEKLY CHECKS

1. Chassis locking mechanism.
2. Armrest adjustment knobs.
3. Allow battery charger to go through a full recharge cycle. Wait until the green light illuminates.
4. Clean paintwork with auto shampoo. **DO NOT** use harsh abrasives or power washer.



### MONTHLY CHECKS

1. Tyre wear, replace as necessary.
2. All fasteners and fittings for sound function.
3. Motor brush wear condition.
4. Battery connections.
5. Inspect all electrical plugs and sockets for damage, good contact and fit.

### YEARLY CHECKS

1. Front wheel bearings for wear.
2. Handlebar bearings.
3. Rear drive wheel hub keys.
4. All wheel bolts.
5. Drive axle securing bolts.
6. Motor mounting bolts.
7. Magnetic motor brake disc and function.
8. Main wiring loom for damage.
9. All steering components.
10. Clean chassis and repaint any exposed parts.
11. Replace any damaged axle seals.
12. Cycle charge for full operation function.
13. Cycle test batteries for operating capacity. (Ask your Authorised Dealer for details.)

## IX. OPTIONAL ACCESSORIES

		
Arms Bag	Crutches Bucket	

Scooter is a one piece mobility scooter with optional accessories for your convenience. For information regarding these optional accessories listed above, please contact your authorised dealer.



### Warning!



**DO NOT overload accessories as this will affect the weight capacity of your scooter and decrease stability.**



# X. WARRANTY TERMS

## **Please keep a note of your serial number**

(This is located on the frame tube, under the front chassis).

*Please fill out the following information for quick reference:*

<b>Serial number:</b> _____
<b>Motor number:</b> _____
<b>Controller Number:</b> _____
<b>Charger Number:</b> _____

Your scooter is basically warranted for 12 months from the date of purchase against faults arising due to defects in manufacture or materials on electronic components. This warranty does not detract from, but is in addition to your legal rights. Parts replaced or repaired under the terms of this warranty will be covered for the balance of the period. This warranty applies only to parts supplied or approved by your authorised dealer. Refer to your warranty sheet for additional details. Due to the individual prescription nature of this product, this warranty is not transferable.

*Note: Optional extended warranty insurance may be available from your authorised dealer.*

## **EXCLUSIONS**

This warranty does not extend to consumable items which may need replacing due to normal wear and tear, namely tyres, punctures, lubrication, mats, oil seals, gaskets, screws, upholstery, motor brushes fuses, batteries, handgrips etc. or to damage to the product caused by misuse, neglect or accident. This warranty does not apply if there are signs of excessive wear and abuse or the scooter has been modified without the written authority of FreeRider.

### **The following items are not covered by your warranty:**

- Any noise or vibration, which does not affect the quality and function of the scooter.
- Damage due to lack of maintenance or improper use or operation or storage.
- Fees for the regular service inspection and maintenance.
- Any fees incurred as a result of warranty repair, losses or compensation because of the inability to use the scooter (telephone use, shipping, car rental, fees etc.).

## **METAL WORK**

Components, such as the frame work and bright metal parts require special attention and may deteriorate in certain conditions. Moisture and salt may corrode parts if left unattended for a period of time. Auto cleaner polishes should be used to prevent long term damage. Failure to clean and protect these components may void your warranty.

## X. WARRANTY TERMS

### PAINT WORK

This warranty does not cover deterioration of paint resulting from the lapse of time (e.g. natural fading). It is the user's responsibility to clean and protect the painted surfaces.

### SPEED CONTROLLER

Servicing of the speed controller or battery charger must only be carried out by your local authorised dealer. Any attempt to open or dismantle these items render the warranty void on that item immediately.

### BATTERY

Batteries carry a limited 12 months warranty from the original manufacturer which is subject to a stringent wear and tear clause. Any battery faults due to a defect in the original manufacture will normally become obvious within the first two months of use. (See battery charging section of this manual for additional details.) Any gradual deterioration in the performance after this period is normal and associated with fair wear and tear, misuse or accidental damage and as such are not covered by the manufacturer's warranty. (Battery is warranted as a single part, only the failed part is replaceable.)



## Warning!



**DO NOT attempt to open the battery. Breaking the battery seal will void the warranty on the battery.**

### SERVICE CHECKS

In line with all mobility vehicles, your scooter will benefit from regular service inspections to keep it in a pristine condition. The frequency of these service inspections will depend on the amount of the use of your scooter. We strongly recommend you contact your local authorised dealer to arrange for a service visit. It is recommended that you fully service your scooter at least every 12 months or more frequently depending on the use. The warranty on your scooter may not apply if routine maintenance is not carried out as defined in the Care and Maintenance section of "FreeRider Safety Guide".

### SERVICE CHECKS AND WARRANTY SERVICE

If your scooter should need attention due to failure as defined under the warranty terms, please contact the dealer from whom you purchased your scooter. The scooter shown and described in this manual may not be exactly identical in every detail as your own scooter. However, all instructions are still entirely relevant, irrespective of detail differences. If you are unsure of any details mentioned in this manual, please consult your authorised dealer before driving your scooter. Warranty service checks must be performed by an authorised dealer and will generally be valid at the location where you purchased your scooter. All the transportation costs and shipping damage incurred while submitting parts for repair or replacement are the responsibility of the purchaser.

## XI. SERVICE RECORD

This section is designed to assist you in keeping records of any service and repairs done to your scooter. If you should decide to sell or exchange your scooter in the future, this will prove most helpful to you. Your service agent will also benefit from a documented record. This manual should accompany the scooter when service or repair work is carried out. The service agent will complete this section and return the manual to you.

DETAILS OF WORK CARRIED OUT	DEALER STAMP		
	<table style="width: 100%; border: none;"> <tr> <td style="width: 50%; border: none;"><b>DATE</b></td> <td style="width: 50%; border: none;"><b>INITIALS</b></td> </tr> </table>	<b>DATE</b>	<b>INITIALS</b>
<b>DATE</b>	<b>INITIALS</b>		

DETAILS OF WORK CARRIED OUT	DEALER STAMP		
	<table style="width: 100%; border: none;"> <tr> <td style="width: 50%; border: none;"><b>DATE</b></td> <td style="width: 50%; border: none;"><b>INITIALS</b></td> </tr> </table>	<b>DATE</b>	<b>INITIALS</b>
<b>DATE</b>	<b>INITIALS</b>		

DETAILS OF WORK CARRIED OUT	DEALER STAMP		
	<table style="width: 100%; border: none;"> <tr> <td style="width: 50%; border: none;"><b>DATE</b></td> <td style="width: 50%; border: none;"><b>INITIALS</b></td> </tr> </table>	<b>DATE</b>	<b>INITIALS</b>
<b>DATE</b>	<b>INITIALS</b>		

DETAILS OF WORK CARRIED OUT	DEALER STAMP		
	<table style="width: 100%; border: none;"> <tr> <td style="width: 50%; border: none;"><b>DATE</b></td> <td style="width: 50%; border: none;"><b>INITIALS</b></td> </tr> </table>	<b>DATE</b>	<b>INITIALS</b>
<b>DATE</b>	<b>INITIALS</b>		

# XI. SERVICE RECORD

DETAILS OF WORK CARRIED OUT	DEALER STAMP
	DATE                      INITIALS

DETAILS OF WORK CARRIED OUT	DEALER STAMP
	DATE                      INITIALS

DETAILS OF WORK CARRIED OUT	DEALER STAMP
	DATE                      INITIALS

DETAILS OF WORK CARRIED OUT	DEALER STAMP
	DATE                      INITIALS

YOUR LOCAL DEALER

TO BE FILLED IN BY LOCAL DEALER

**freerider<sup>®</sup>**

**Headquarter and Kaohsiung Facility:**

No.22, Bengong 5th Rd., Gangshan Dist., Kaoshiung City 820, Taiwan(R.O.C.)

TEL: 886-7-6223093      FAX: 886-7-6230373

EMAIL: sales@freerider.com.tw

www.freerider.com.tw

www.luggie.com.tw

2018.June-V1

